



An Electrical Analogue for Analysis of Tracer Distribution Kinetics in Biological Systems

Author(s): J. R. MacDonald, E. G. Perry, L. L. Madison, D. W. Seldin

Source: *Radiation Research*, Vol. 6, No. 5 (May, 1957), pp. 585-601

Published by: Radiation Research Society

Stable URL: <http://www.jstor.org/stable/3570455>

Accessed: 03/04/2009 08:07

Your use of the JSTOR archive indicates your acceptance of JSTOR's Terms and Conditions of Use, available at <http://www.jstor.org/page/info/about/policies/terms.jsp>. JSTOR's Terms and Conditions of Use provides, in part, that unless you have obtained prior permission, you may not download an entire issue of a journal or multiple copies of articles, and you may use content in the JSTOR archive only for your personal, non-commercial use.

Please contact the publisher regarding any further use of this work. Publisher contact information may be obtained at <http://www.jstor.org/action/showPublisher?publisherCode=rrs>.

Each copy of any part of a JSTOR transmission must contain the same copyright notice that appears on the screen or printed page of such transmission.

JSTOR is a not-for-profit organization founded in 1995 to build trusted digital archives for scholarship. We work with the scholarly community to preserve their work and the materials they rely upon, and to build a common research platform that promotes the discovery and use of these resources. For more information about JSTOR, please contact support@jstor.org.



Radiation Research Society is collaborating with JSTOR to digitize, preserve and extend access to *Radiation Research*.

<http://www.jstor.org>

An Electrical Analogue for Analysis of Tracer Distribution Kinetics in Biological Systems¹

J. R. MACDONALD AND E. G. PERRY

Research Division, Texas Instruments, Inc., Dallas, Texas

AND

L. L. MADISON AND D. W. SELDIN

Department of Internal Medicine, The University of Texas Southwestern Medical School, Dallas, Texas

INTRODUCTION

The instrument to be described was designed to solve rapidly and accurately the problem of transfer of a tracer substance from one fluid compartment in a biological system into as many as four other compartments. As distribution occurs from the volume into which a known amount of the tracer is initially injected, the tracer concentration in this volume decreases, while those of the other volumes increase from zero. Initially, all the volumes and the flow rates between the volumes are unknown. These quantities must be extracted from measurements of the tracer concentration as a function of time in one or more of the accessible volumes of the system. When the system is linear and the volumes and rates are constant during the experiment, these concentration curves are composed of sums and differences of exponentials (1). If the volumes and flow rates are known, it is a simple matter to calculate the concentration curves. The reverse calculation is a different matter, however, and, when more than three separate volumes are involved, it is virtually impossible in practical cases to calculate the system parameters from knowledge of the concentration curves. The present machine, by making use of an electrical analogy of the biological system, eliminates the need for such calculations. In electrical terms, it allows a circuit synthesis to be carried out so that system parameters are obtained from the transient response of the system to an impulse applied at $t = 0$. Although it was built specifically for a medical application, the machine is applicable to diffusion problems occurring in many diverse fields.

¹ This research was supported in part by grant No. H-1635 (C2) from the United States Public Health Service. A preliminary version of this work was presented at the National Simulation Conference, Dallas, Texas, January 21, 1956. This paper is being published as a supplement under special arrangement between the Radiation Research Society and the authors' laboratory in recognition of the special circumstances which make this advisable.

The specific medical purpose for which the present instrument was designed is the intercompartmental transfer by diffusion of radioactive sulfate, $S^{35}O_4$, injected intravenously into human subjects. Since only a few micrograms of labeled sulfate is thus injected, the normal blood sulfate concentration remains essentially undisturbed. In normal subjects, the tracer rapidly mixes with the blood and diffuses into the rest of the extracellular fluid (ECF). It is assumed that such mixing occurs in a time short compared with the volume-to-volume diffusion processes. Tracer is also removed from the blood by the kidneys and eventually appears in the urine. From the extracellular volume, a small amount of tracer diffuses into the cells. In patients with edema and/or ascites, diffusion also occurs into these expanded portions of the extracellular volume.

The blood plasma compartment of the body represents a fairly well-defined single volume. On the other hand, many of the other volumes with which we are concerned, such as the cell volume, represent the sum of a large number of separate elemental volumes. The lumping of such elements into a single "average" volume usually turns out to be an excellent approximation. The volume of a compartment in a tracer experiment is not necessarily its total physical volume but, by definition, is that part of such volume which is accessible to the tracer employed. Thus, at final equilibrium, the magnitude of the compartment as measured by the specific tracer used will be proportional to the amount of labeled material (proportional to counting rate for a radioactive tracer) in the compartment. Therefore, the volumes with which one is concerned in a tracer experiment should be designated "tracer spaces," e.g. "radiosulfate space," in the present experiment. In many cases, a tracer material can be found whose corresponding volumes of distribution approximate quite closely to the physical volumes of interest in the biological system.

The above picture, and its corresponding translation to electrical terms, is correct only if it is assumed that uniform concentration of tracer within any compartment is achieved by mixing and internal diffusion in a time short compared to the time required for intercompartmental diffusion. Although this condition is only approximately met in practice in some compartments, the good agreement often obtained between theory and experiment indicates that it is usually not of paramount importance.

THE DIFFUSION ANALOGUE

When the equilibrium state of a biological system involves concentration differences across membranes, diffusion is not necessarily the driving force for tracer transfer across the membrane. In such a case, the differential equations governing radioactive tracer distribution between two volumes, v_a and v_b , should be written in terms of specific tracer activities, s_a and s_b , where these quantities are defined as counting rate per unit mass of tracer carrier material in each volume. The equations then are²

² Lower-case letters are used throughout for the parameters of the biological system, and upper-case letters for those of the corresponding electrical system.

$$\left. \begin{aligned} \frac{ds_a}{dt} &= -k_{ab}s_a + k_{ba}s_b \\ \frac{ds_b}{dt} &= -k_{ba}s_b + k_{ab}s_a \end{aligned} \right\} \quad (1)$$

where k_{ab} is a rate constant for tracer mass transfer from v_a to v_b , and k_{ba} is that for v_b and v_a . These rate constants obviously have units of 1/time.

In the biological problem which the present machine was designed to solve, it is a good approximation to assume that the final equilibrium state of the system is that of equal solute concentrations in all volumes of distribution. For this case transfer occurs by diffusion, and the above equations may be rewritten in terms of tracer concentrations (or quantities proportional thereto, such as counting rate per unit volume). We then obtain

$$\left. \begin{aligned} \frac{dm_a}{dt} &= v_a \frac{dc_a}{dt} = -\rho_{ab}(c_a - c_b) \\ \frac{dm_b}{dt} &= v_b \frac{dc_b}{dt} = -\rho_{ab}(c_b - c_a) \end{aligned} \right\} \quad (2)$$

where $\rho_{ab} = \rho_{ba} = k_{ab}v_a = k_{ba}v_b$ is a flow rate from v_a into v_b or v_b into v_a . The quantities m_a and m_b are tracer masses and will be expressed in terms of counting rate if the c 's are given in terms of counting rate per unit volume.

The electrical system obeying equations analogous to those of equations 2 is just a resistor connected between two capacitances. The differential equations in the electrical case are, therefore,

$$\left. \begin{aligned} \frac{dQ_a}{dT} &= C_a \frac{dV_a}{dT} = -\frac{1}{R_{ab}}(V_a - V_b) \\ \frac{dQ_b}{dT} &= C_b \frac{dV_b}{dT} = -\frac{1}{R_{ab}}(V_b - V_a) \end{aligned} \right\} \quad (3)$$

where Q is electric charge, V voltage, C capacitance, and R resistance.

Comparison of the two sets of equations allows us to write the following transformation equations:

$$\begin{aligned} m \text{ (kilocounts/min)} &= [\delta] [Q \text{ (}\mu\text{coulombs)}] \\ t \text{ (hours)} &= [\epsilon] [T \text{ (seconds)}] \\ v \text{ (liters)} &= [\delta/\lambda] [C \text{ (}\mu\text{farads)}] \\ c \text{ (counts/min-cc)} &= [\lambda] [V \text{ (volts)}] \\ \rho \text{ (liters/hr)} &= [\delta/\epsilon\lambda] [R \text{ (megohms)}]^{-1} \end{aligned}$$

The conversion factors, denoted by Greek letters, are chosen so that the relations $m = vc$, $Q = CV$, and $v/\rho = \epsilon RC$ hold as they should.

The results of a biological experiment are the initial tracer charge, m_0 , and one or more curves of concentration versus time. The essence of the use of an electrical analogue for analyzing such curves is to derive from it voltages, $V(T)$, which can, in some fashion, be compared with the experimental concentration curves. Then, the analogue elements, applied voltage, etc., are adjusted until $V(T)$ versus T is of the same form as one of the concentration curves. The conversion factors may then be evaluated and used in conjunction with the final values of the electrical parameters to yield the desired volumes and rate constants of the biological system which led to the experimental curves. Since different concentration curves may often be obtained from concurrent measurements in two or more separate volumes of the biological system, whereas analysis of the system can often be carried out with only one such curve, a valuable internal check of the correctness of the assumed biological model is available. When only one curve is used to obtain the system interconnection and parameters, the output of the analogue may be then switched to yield a voltage proportional to the concentration in another volume. Good agreement indicates that the model and parameter choice obtained from the analogue are good approximations for the actual system.

DESCRIPTION OF APPARATUS

In this machine, accurate comparison between the cycled output of the electrical analogue and the biological experimental data is carried out by using a graph on which are plotted the experimental concentration curves. The analogue output appears on the graph as a light spot swept across the graph in the $+x$ direction once each cycle. The spot is derived from a fast-acting galvanometer and is used to plot out the analogue output on the graph. High accuracy is achieved with this comparison method, and the analogue elements may be rapidly adjusted to make the spot follow a given experimental curve over its entire length.³

The possible interconnections of the five analogue capacitors and resistors are shown in Fig. 1*a*. There are six distinguishable combinations, of which the three most important are shown in Fig. 1*b*, 1*c*, and 1*d*. The final combination is that which experimental evidence shows represents the biological system when edema and/or ascites are present. The electrical elements of the analogue are labeled, for convenience, in terms of the corresponding volumes of this biological system. The initial amount of radioactive tracer, m_0 , is usually injected into the blood and corresponds to an initial charge, Q_0 , on the blood capacitor, C_B . Some of the charge flows out with the urine through the resistor R_u . In addition, equilibrium between the tracer in the blood and that in the remaining part of the ECF volume, repre-

³ Since the design of the present instrument was completed, a report of a somewhat similar analogue machine has been found (2). This uses a much shorter time scale than the present instrument, and the method of comparing the analogue output with experiment is less convenient and accurate.

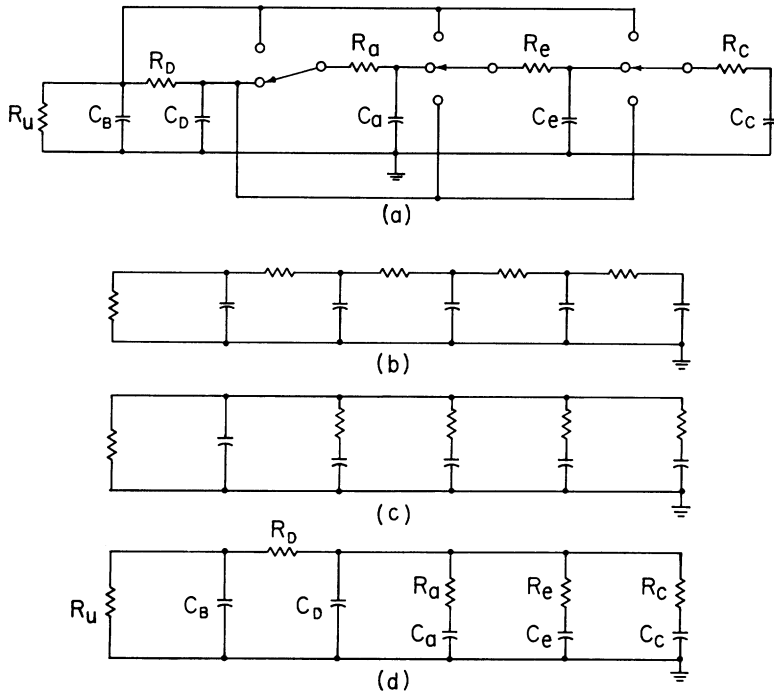

Fig. 1. Interconnection of analogue elements. (a) Switching arrangement. (b) Catenary system. (c) Mammillary system. (d) Edema-ascites system.

sented by C_D , is rapidly attained. Also, tracer (or charge) diffuses from C_D more slowly into the other volumes (or capacitances) of the system: the cell volume, the edema volume, and the ascites volume.

The analogue capacitances are each made up of 1% Mylar-dielectric decades covering a range from $11.11 \mu\text{f}$ to $0.001 \mu\text{f}$. The resistors are each three-decade plug-in units (Fig. 2) and have maximum values ranging in steps of 10 from 9.99 megohms to 0.00999 megohm. The resistance tolerance on each plug-in unit is also 1%.

A simplified electrical block diagram of the system is shown in Fig. 3. An accurately known capacitor charging voltage, V_0 (0 to 10 volts), is derived from a highly stabilized voltage source and a ten-turn helipot. In order to obtain repeated outputs from the analogue, it is cycled with a period of 1.5 seconds. At the beginning of each cycle, one capacitor of the analogue is charged to V_0 and then discharges for 1.0 second into the rest of the system, which is initially uncharged. During the remaining 0.5 second of each cycle, all the remaining capacitors are shorted and the selected capacitor, usually C_B , is charged. This sequence of events is diagramed in Fig. 4. The top curves show the decay of the voltage on the charged

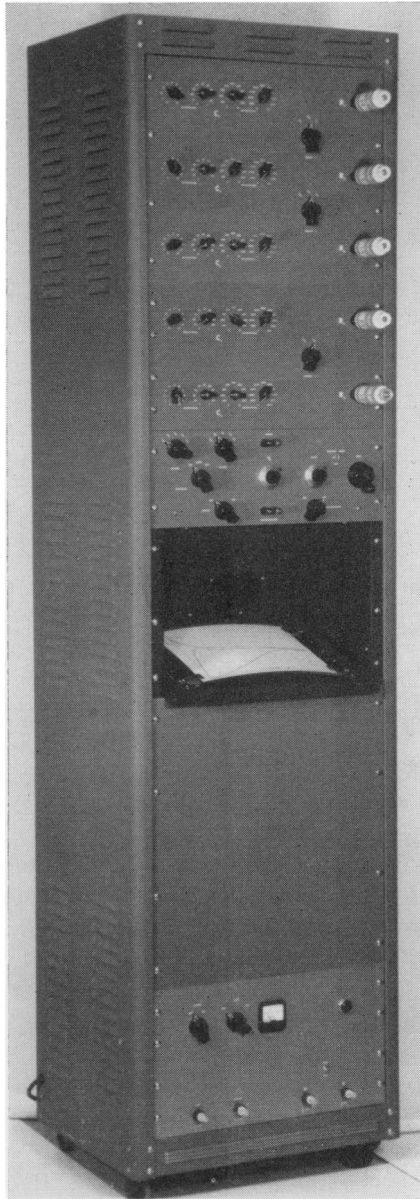

FIG. 2. Photograph of the analogue machine. Analogue components are located in the upper section with the plug-in resistance decades at the right. Next follow the amplifier and switching chassis, the graph region, and the power supply. The graph-paper support is inset within the instrument somewhat to reduce the incident light level. For operation under very high ambient light level conditions, an additional metal shield swings out from the machine to shield the graph region even further.

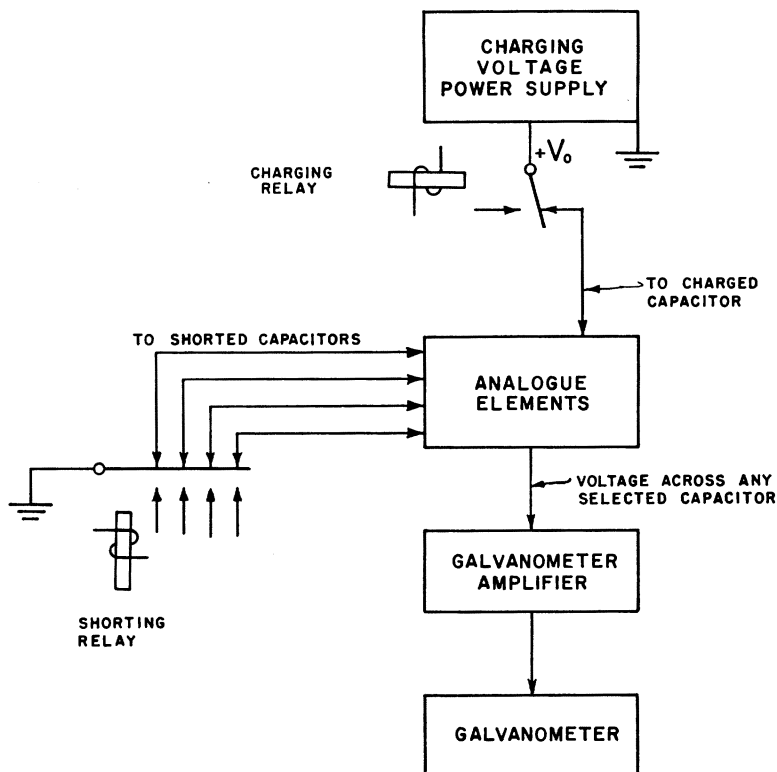

FIG. 3. Electrical block diagram.

capacitor, and the bottom ones refer to one of the other analogue capacitances. To obtain precise and reproducible initiation of each cycle, the switching relays are energized electrically at the beginning of the cycle rather than at the end.

Figure 3 also shows that the voltage output of the analogue taken from any selected capacitor passes to a very-high-input-impedance feedback amplifier whose current output, which is accurately proportional to the input voltage, drives a galvanometer. The circuit of this amplifier, an improved version of that described by Valley and Wallman (3), is presented in Fig. 5. Both negative and positive feedback are used, and it is flat to over 10^3 cps. The floating-point adjustment in the cathode circuit of the first tube allows the input grid potential when floating disconnected to be adjusted to exactly ground potential. For incremental signals around ground potential, its input impedance is then infinite. For voltage swings as large as +10 volts, it is still more than 500 megohms with a 12BZ7 for the input tube and is greater than 1000 megohms for a 5-volt swing. With this high an input impedance, the voltage across a given capacitance is left essentially un-

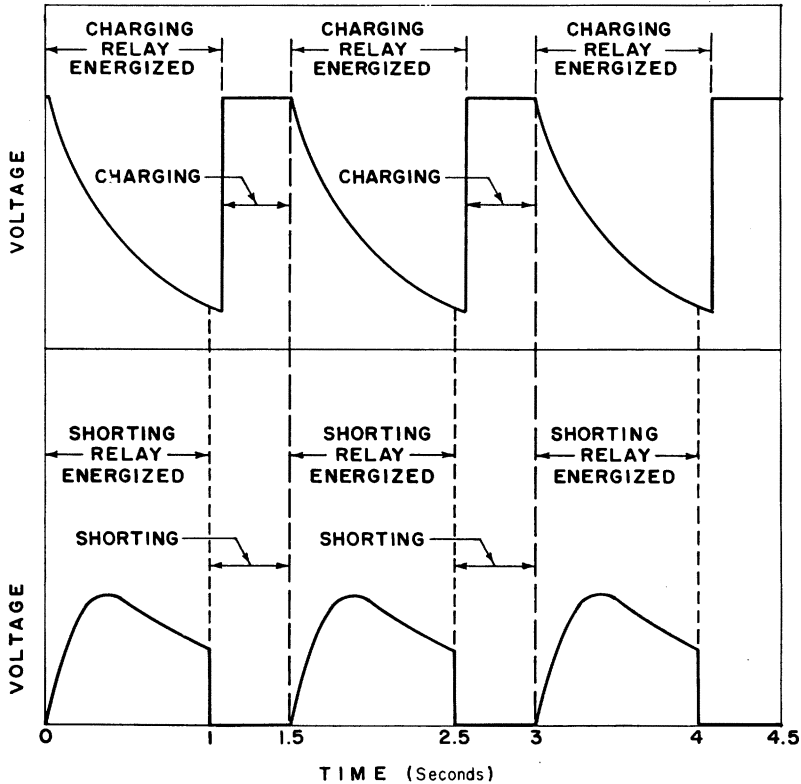

Fig. 4. Cycling details. Upper wave shape is that across the charged capacitor, lower across one of the other analogue capacitors.

changed during a cycle by connection of the amplifier input to the capacitance. To improve the stability of the floating point, the heater voltage of the amplifier is regulated.

Comparison of the analogue output during a cycle and experimental concentration curves is accomplished by means of the galvanometer, as shown in the mechanical block diagram of Fig. 6. The galvanometer spot (0.06 inch in diameter) is focused by a curved mirror at the galvanometer on a piece of graph paper on which the experimental curves have been plotted. The y -axis deflection of the spot is proportional to the voltage on the capacitance of the analogue selected for study. In addition, there is an x -axis sweep so adjusted that the spot traverses the entire marked long axis of the graph paper in exactly a second. This sweep is derived from the sweep cam and mirror system shown. The cam follower tilts the sweep mirror so as to change the angle of reflection and moves the spot across the paper. The cam system is driven by a hysteresis-synchronous motor, and the sweep cam

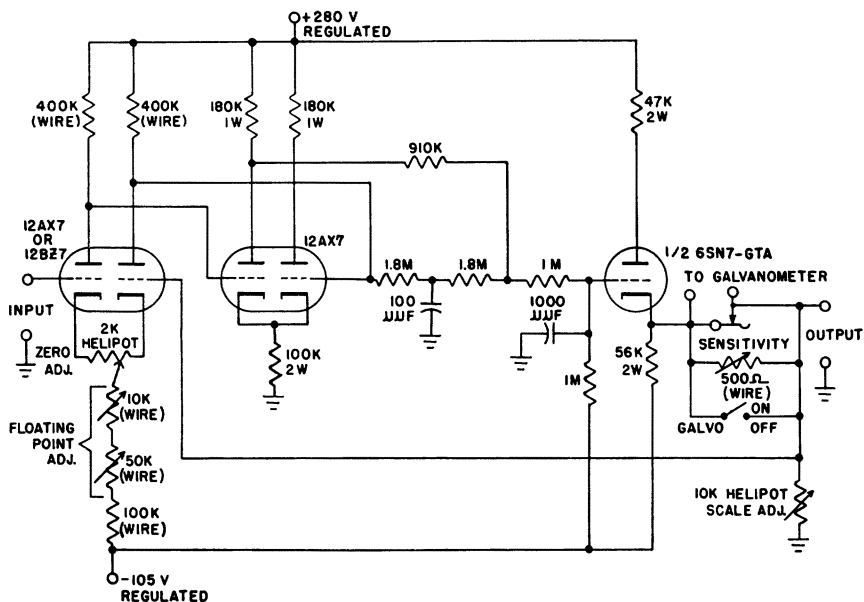

FIG. 5. Circuit diagram of galvanometer amplifier.

is accurately cut; thus, the sweep is highly linear. The cam incorporates a fast retrace section. The drawing shows the cam almost at the end of the sweep and about to begin the fast return.

Synchronism between the electrical charge-discharge cycle and the x -axis spot sweep is accomplished by turning on the charging and discharge relays by separate microswitches which, in turn, are actuated by cams rigidly connected to the sweep-cam shaft. The beginning of the cycle when the charged capacitor begins to discharge is made to occur by this means at exactly the time that the galvanometer spot reaches $x = 0$ and starts along the marked portion of the graph paper.

A retrace blanking cam (Fig. 6) eliminates the spot during the 0.5-second retrace time. The semitransparent graph paper containing the experimental curves is clamped at the corners over a transparent plastic surface, curved along the x -axis to reduce optical errors. It is viewed from above.

The galvanometer, of low mass and rapid action, with a natural resonant frequency of several hundred cycles, is damped by the 0- to 500-ohm sensitivity rheostat (Fig. 5). Another sensitivity adjustment is afforded by the "scale" helipot (Fig. 5) that controls the magnitude of the total current which passes through the galvanometer and its damping resistor for a given input voltage. With 500 ohms damping, the sensitivity of the system is such that, for any applied voltage from 10 to 0.1 volt, more than seven times as great a current may be applied to the galvanometer as is required to displace the spot the full length of the y -axis on the

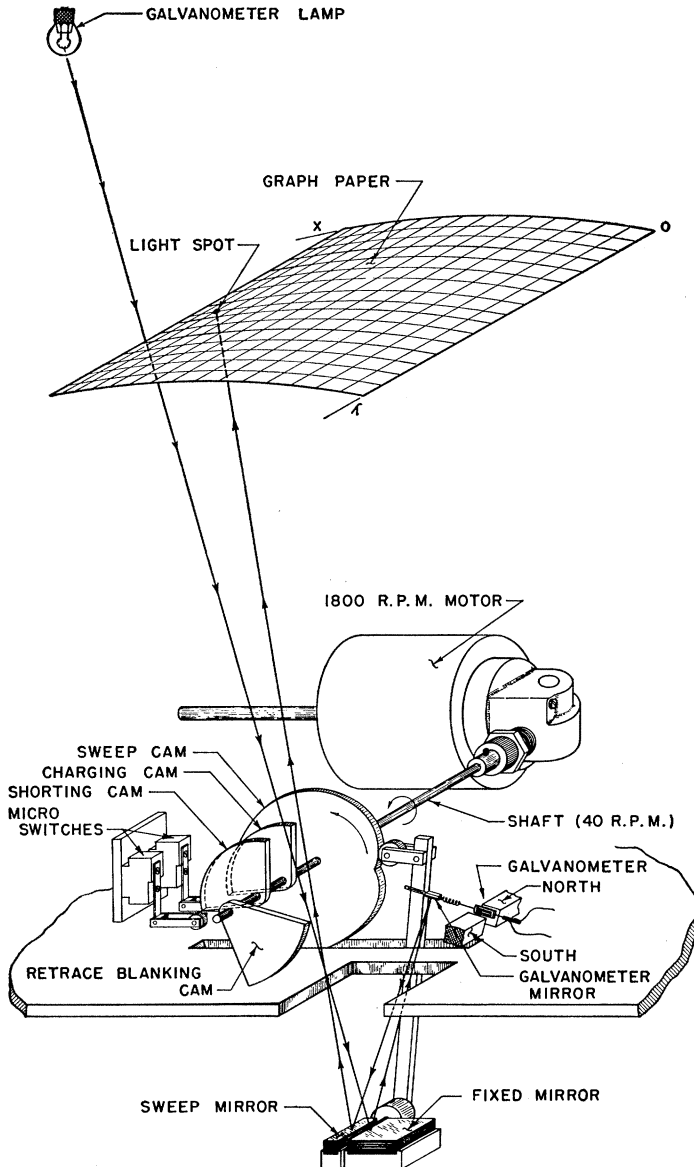

FIG. 6. Mechanical and optical arrangement diagram.

graph. When the sensitivity is further increased by decreasing the scale resistance even more, the linear relation between input voltage and output current suddenly fails as the amplifier is called on to deliver more current than it is capable of handling.

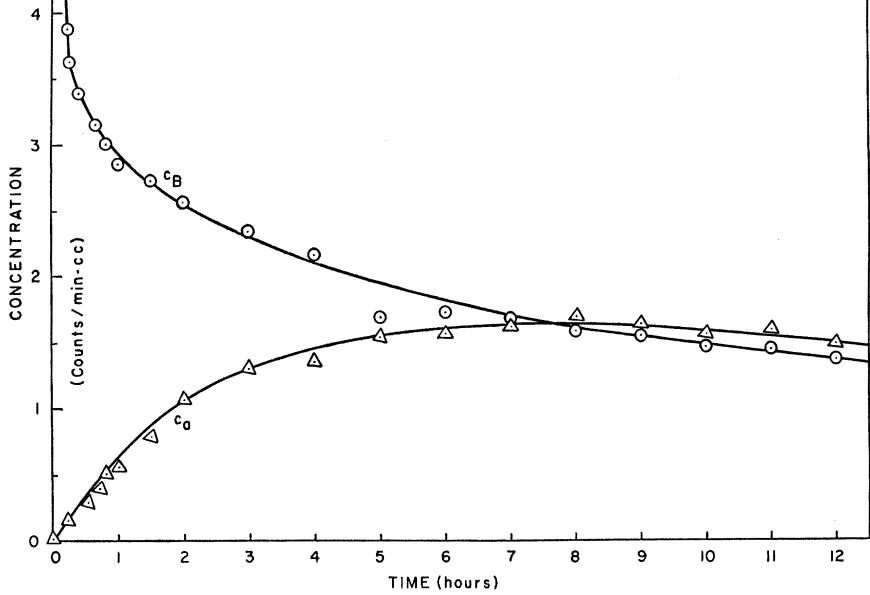

FIG. 7. Comparison of experimental and analogue time curves of disappearance of S^{35} from the plasma and time curves of appearance into ascitic fluid. The experimental points are enclosed in a circle (plasma) or triangle (ascites). The solid curved lines were drawn by recording the path of the light spot on the graph after best adjustment of the analogue elements,

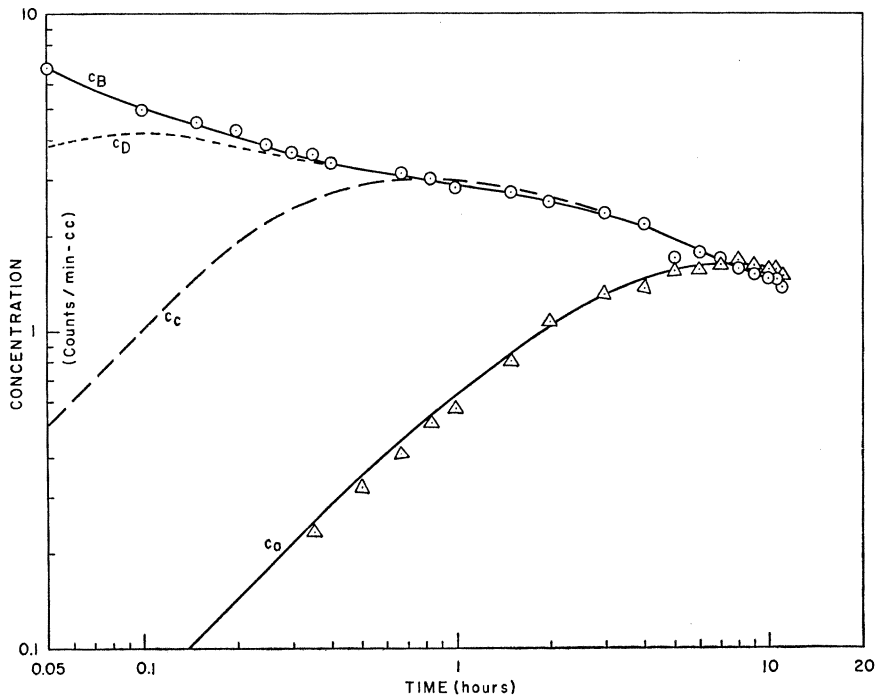

FIG. 8. Log-log plot showing medical data and curves obtained from analogue fitting with different time scales.

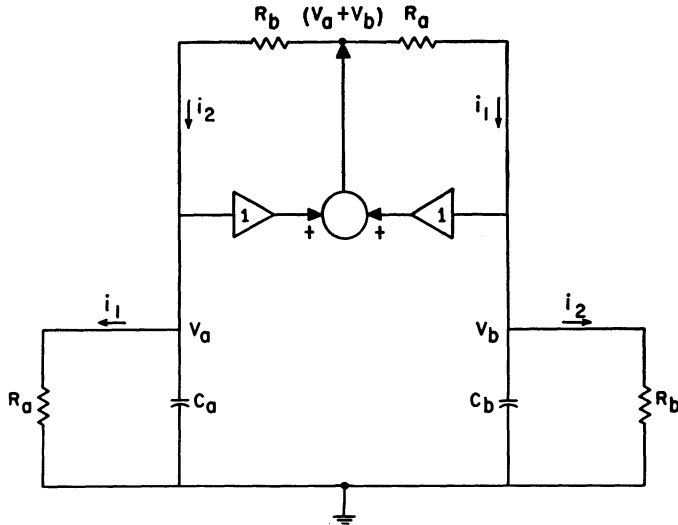

FIG. 9. Simple electrical circuit for simulation of diffusion between two volumes with unequal forward and reverse diffusion.

To operate the machine, the graph paper, with experimental curves plotted, is positioned so that the cycle begins at $x = 0$, and the spot follows the x -axis with zero applied voltage. Analogue elements and applied voltage are then adjusted until the spot follows one of the curves as closely as possible over its entire length. Finally, for checking purposes, the amplifier input may be switched to another of the analogue capacitors corresponding to one of the additional experimental curves on the graph, and the degree of fit observed between the spot motion and the selected curve.

Despite the absence of spot persistence, it is a simple matter to adjust the analogue elements to achieve correspondence between experiment and analogue. Further, the analogue output can be taken from one of the capacitors which represents an inaccessible volume in the biological system, such as the cell volume. Hence, valuable information is obtained concerning concentration changes in such volumes. Finally, after analogue adjustment the paths of the spot for all the different capacitances can be accurately drawn on the graph in a very short time, yielding a permanent record of the concentration curves for all the volumes of the system. Alternatively, a permanent record can be obtained when photographic paper is used in place of the graph paper. Since the tracer is not always injected into the blood, provision is made that any of the five analogue capacitors can be charged while all the others are shorted during retrace. In addition, the voltage across any one of the capacitors can be used to drive the galvanometer.

PERFORMANCE

The intrinsic linearity of the system was first assessed by static methods. With no current through the galvanometer, the sweep motor may be turned by hand and the spot positions noted on the graph for each of the thirty full revolutions required for the spot to traverse the x -axis completely. Such a test was carried out and the deviations from linearity evaluated. The deviations found were almost too small to observe and were less than 0.5% of the full sweep length anywhere in the sweep.

A static test of the y -axis linearity for various x values can be carried out by plotting V_0 , as read off the helipot dial, versus the y -axis spot position from full deflection to zero. Again, the maximum deviation was found to be extremely small and certainly amounted to no more than 0.5% of full deflection.

A dynamic test of the system as a whole is afforded by fitting to single exponential decay curves. A number of such theoretical curves having time constants varying over a range of several hundred were plotted on the same graph. Then, with a single analogue resistance and capacitance, the corresponding time constant was adjusted to make the spot follow one of the theoretical curves. It was found that this was possible for all the curves and that the degree of fit was equally good on all. Because the fit was so good, it was difficult to estimate the maximum error. As far as the eye could tell, it was possible to make the spot follow any of the curves exactly. Thus, the dynamic error is also of the order of 0.5% or less.

Although the intrinsic accuracy of the machine, including the analogue elements, is of the order of 1%, it is not always possible to derive the system parameters from a single experimental curve to this accuracy even in the absence of any error in the experimental data on which the curve is based. Even though the shape of any curve is determined by all the elements of the system and the element values are unique for a given system, the curve shape will be a more sensitive function of some elements than of others. Although added accuracy can be obtained by carrying out the analysis in steps by plotting the data on a graph with several different time scales, analyzing the curves for the shortest scale first, then using the resulting analogue element values in fitting the next, and so on, there are some cases where element changes of as much as 10% or more produce no very appreciable change of the curve followed by the galvanometer spot. This will be particularly the case if the element changed is separated by several diffusion constants (resistances) from the capacitance whose voltage is observed.

The situation is quite different when more than one concentration curve can be obtained. Then, the voltages across the capacitors corresponding to the volumes associated with these additional curves may be directly compared with the concentration curves and a much more sensitive adjustment of the parameter values is possible. Were curves available for all the volumes of the system, all the parameters could be found to within 1 or 2%. In the edema-ascites case, one curve is generally

available when three volumes are present, two with four volumes, and three with five volumes. The accuracy of the elements of the system derived from the analogue will generally range from 1 or 2% for the most sensitive elements to 5 to 10% for those least sensitive whose concentration curves are unavailable.

These conclusions are illustrated in Figs. 7 and 8, which show experimental points derived from a patient with ascites and solid curves drawn by recording the path of the light spot on the graph after best adjustment of the analogue elements. Figure 7 shows the fit obtainable for the blood and ascites concentration curves plotted on a linear scale 12.5 hours long. It shows the details of the curves clearly from 1 hour on. The log-log presentation of Fig. 8 is included to show the curves in more detail for short times. To obtain the machine-produced curves shown in Fig. 8, the medical data were plotted on a linear graph such as Fig. 7 three times, with scale lengths of 12.5, 2.5, and 0.625 hour. The capacitance settings were kept constant, and the analogue resistances were increased by factors of first 5 and then 4 to pass from the curves of 12.5- to 2.5-hour scale lengths, and from those of 2.5- to 0.625-hour lengths. In this fashion, accurate adjustment of those parameters such as C_D and R_D of most influence at short times could be carried out. The analogue curves recorded on these graphs of different time scales were then replotted in Fig. 8.

Figure 8 shows machine-derived curves for c_D and c_c as well as for c_B and c_a . Most of the initial rise of the c_D curve occurs in less than 0.05 hour. The fact that the machine curve for c_a lies somewhat above the experimental points for short times may possibly indicate incomplete mixing in the ascites volume for times less than about an hour. The electrical and mechanical system data derived from the analogue are summarized below. The value of m_0 was 58.470 kilocounts/min.

$C_B = 0.400 \mu\text{f}$	$v_B = 3.43 \text{ liters}$	
$C_D = 0.96 \mu\text{f}$	$v_D = 8.2 \text{ liters}$	$V_0 = 10.0 \text{ volts}$
$C_a = 1.10 \mu\text{f}$	$v_a = 9.4 \text{ liters}$	$\delta = 14.6 \text{ kilocounts/}$
$C_c = 0.60 \mu\text{f}$	$v_c = 5.2 \text{ liters}$	$\text{min-}\mu\text{coulombs}$
$R_u = 0.80 \text{ M}\Omega$	$\rho_u = 0.86 \text{ liters/hr}$	$\lambda = 1.70 \text{ counts/min-cc-}$
$R_D = 8.0 \text{ K}\Omega$	$\rho_D = 86 \text{ liters/hr}$	volts
$R_a = 0.33 \text{ M}\Omega$	$\rho_a = 2.1 \text{ liters/hr}$	$\epsilon = 12.5 \text{ hr/sec}$
$R_c = 36.0 \text{ K}\Omega$	$\rho_c = 19.1 \text{ liters/hr}$	

Note that the ρ flow rates given here do not represent actual fluid transfer rates but instead only measure solute transfer rates. They may be converted to the k rate constants introduced initially by dividing by their pertinent volumes; thus, $k_D = \rho_D/V_D = 10.5 \text{ hr}^{-1}$.

Experimentally, it was found using the machine that the blood plasma and ascites concentration curves were somewhat insensitive to the cell volume and

flow rate, ρ_c . Since this volume is relatively small, it is clear that it is not the true physical cell volume of the patient but is a tracer-space volume only. It is found that both the volume and the diffusion rate associated with this compartment depend strongly on the physical condition of the subject, and it appears that "cell" volume obtained from experiments of the present nature is probably associated with metabolic reactions involving tracer material within some but not all the body cells. For convenience, we shall continue to designate this compartment as the cell volume. In the present machine, penetration of tracer into the cells can only be treated as a simple diffusion process; in actuality, the process may involve transfer with widely different forward and reverse flow rates. This subject will be discussed at more length in the next section.

FURTHER DEVELOPMENTS

The machine was initially designed to handle transient diffusion problems. It could be easily augmented to handle more than five volumes if the data to be analyzed warranted. Further, a useful modification would employ mechanical gearing to change the actual sweep time and make available, say, times of 0.4, 1.0, 3.0, and 10 seconds. This would make it more convenient to analyze experimental curves plotted to different time scales than the present method of changing all the RC time constants when passing from one ϵ scale factor to another. Finally, flow of tracer material from any volume to ground (out of the system of interest) may be handled by connecting a resistor between the corresponding capacitor and ground as is done in the present machine for the flow from the blood through the kidneys and out with the urine.

Brownell *et al.* (2) have discussed steady-state unidirectional flow between volumes of interest. To handle such flow, use is made of a unity-gain isolation amplifier in series with the resistor connecting the two volume capacitors between which flow occurs. The transient bidirectional flow situation is more commonly encountered, however, than that of steady-state flow, where the material flowing out of one compartment is compensated by a corresponding inflow from the outside.

Transient unidirectional flow from one volume to another is a limiting case of transfer between two volumes in which the forward flow rate, ρ_{ab} , differs from the reverse rate, ρ_{ba} . Such differences can arise physically from the presence of semi-permeable membranes, chemical reactions involving the tracer in one volume and not the other, etc. In the case of transient flow in only one direction, either ρ_{ab} or ρ_{ba} will be zero, depending on the direction of flow.

Since transient tracer distribution with unequal forward and reverse rates is of considerable importance in many biological systems, it is of interest to present an electrical circuit for simulating this process. The circuit to be presented is not unique but appears to represent one of the simplest electrical realizations of the

process. When $\rho_{ab} \neq \rho_{ba}$, the mechanical and electrical differential equations may be written as

$$\left. \begin{aligned} v_a \frac{dc_a}{dt} &= -\rho_{ab}c_a + \rho_{ba}c_b \\ v_b \frac{dc_b}{dt} &= -\rho_{ba}c_b + \rho_{ab}c_a \end{aligned} \right\} \quad (5)$$

$$\left. \begin{aligned} C_a \frac{dV_a}{dt} &= -\frac{V_a}{R_a} + \frac{V_b}{R_b} \equiv -i_1 + i_2 \\ C_b \frac{dV_b}{dt} &= -\frac{V_b}{R_b} + \frac{V_a}{R_a} \equiv -i_2 + i_1 \end{aligned} \right\} \quad (6)$$

Note that equations 6 may be also used as the analogue of equations 1 if C_a and C_b are taken equal.

The circuit which realizes equations 6 is shown in Fig. 9. Two unity-gain isolation amplifiers are used. Their input impedance must be large compared to the largest value of R_a and R_b . When the maximum voltage swing is not too large, the circuit of Fig. 5, adjusted for highest input impedance over the voltage range of interest, is suitable for these isolation amplifiers. After warm-up, its zero drift is negligible compared to voltages of 0.1 volt or greater. The outputs of the two isolation amplifiers are added in an accurate feedback-type adder⁴ to yield $(V_a + V_b)$. The currents which flow are indicated on the diagram and sum to the proper values at the V_a and V_b nodes. For convenience of adjustment, the two R_a and the two R_b resistors may each be ganged together.

When only flow from volume a to volume b is present, $\rho_{ba} = 0$ and $R_b = \infty$. Under these conditions, any initial charge on C_a will be transferred to C_b , and the final equilibrium state will be that with $V_a = 0$. Physically, this situation will occur when a wall separating the two volumes allows passage of tracer in the a - b direction through the wall but not in the b - a direction. This circumstance might arise if the tracer molecules were immediately sequestered by a metabolic chemical reaction on their entrance into volume b . If the reaction rate were not infinite, some molecules could diffuse in the reverse direction after entering b ; if such reverse diffusion were large enough to be of importance, a more complicated analogue would be required which might, for example, utilize time-varying diffusion rates (and resistors). Note that the circuit of Fig. 9 with $R_b = \infty$ could be used to sum the charge (or tracer) flowing into the urine, and the voltage V_b compared on the machine with an experimental curve of tracer mass in the urine obtained during the course of an experiment.

⁴ The summing amplifier can be of the general type discussed on p. 99 of ref. 3, but no polarity reversal must occur unless it also occurs in both isolation amplifiers.

When neither ρ_{ab} nor ρ_{ba} is zero, final equilibrium is attained when $i_1 = i_2$. Thus, the loss of charge by the current flow through R_a and R_b to ground is continuously supplied from the output of the summing amplifier. For such dynamic equilibrium to be maintained over lengthy periods, it is necessary that the summing amplifier output be very accurately equal to $(V_a + V_b)$ and that the two R_a and the two R_b resistors be accurately equal. If the circuit of Fig. 9 is used in a cycled analogue, however, equilibrium will usually not be attained during a cycle or at any rate need not be long maintained, and the above degree of accuracy will be unnecessary.

SUMMARY

An electrical analogue for the analysis of tracer distribution kinetics in compartmental biological systems is described. These systems are simulated by a network of five-decade resistors and five-decade capacitors cycled with a 1.5-second period. Voltage curves from the analogue capacitors can be compared directly with graphically plotted tracer concentration curves to high accuracy. Adjustment of analogue elements for correspondence between such voltage and concentration curves allows accurate values of the system interconnection and of tracer volumes of distribution and flow rates to be rapidly obtained. The application of the machine to analysis of concentration curves obtained from human subjects with ascites and/or edema is described. Finally, modifications of the apparatus are discussed which make it applicable where transient flow between volumes or transfer with differing forward and back flow rates is present.

RECEIVED: September 4, 1956

REFERENCES

1. C. W. SHEPPARD and A. S. HOUSEHOLDER, The mathematic basis of the interpretation of tracer experiments in closed steady-state systems. *J. Appl. Phys.* **22**, 510-520 (1951).
2. G. L. BROWNELL, R. V. CAVICCHI, and K. E. PERRY, An electrical analog for analysis of compartmental biological systems. *Rev. Sci. Instr.* **24**, 704-710 (1953).
3. G. E. VALLEY and H. WALLMAN, *Vacuum Tube Amplifiers*, p. 480, McGraw-Hill Book Company, New York, 1948.