

encountered. This counter has been used to measure the direct intensities of neutrons in various experiments. Total cross sections can be obtained readily with the neutrons from thin D_2O targets. Experiments are now in progress involving scattering and cross sections. Again the great advantage of this method is that in a given measurement the pulses corresponding to the neutrons involved can be identified and extraneous backgrounds can be eliminated from the calculations.

The authors would like to thank Dr. S. S. Hanna, Dr. L. Madansky, and Mr. Paul Chagnon for their many helpful discussions and comments. In addition we wish to acknowledge gratefully the assistance of Mr.

R. Slaven and Mr. R. Lee in the operation of the accelerator and associated equipment.

Note added in proof.—It is of some interest to mention one or two additional points concerning the discussion presented in this paper.

The technique of mounting the *trans*-stilbene crystals has been improved. Using the new photomultipliers which have flat photocathodes, one can mount the crystals directly on the photocathode. Also, the use of magnesium oxide as a light reflector applied directly to the side of the crystal seems to give noticeably greater pulse heights from the crystal-phototube system.

The use of the multiple scattering to emphasize the forward edge of the proton recoil distribution seemed to offer many improvements in the techniques of measuring neutron energy spectra. The results of further investigations of the multiple scattering effects have in general been inconclusive. It is possible that this effect is masked by inherently poor resolution or by the nonlinear response of the crystal.

An AC Cathode-Follower Circuit of Very High Input Impedance

JAMES ROSS MACDONALD*

Chemistry Division, Argonne National Laboratory, Lemont, Illinois

(Received May 28, 1953)

A cathode-follower circuit of very high-input impedance using ordinary tubes is described. At the coaxial cable input, the capacitance to ground is less than $0.3\mu\text{mf}$ from below 100 to above 5×10^4 cps. The magnitude of the input resistance is more than 4×10^8 ohms from below 100 to 4700 cps; above 3200 cps, its sign is negative and it decreases with frequency. A comparison of theoretical and experimental results is given and a stable modification of the circuit discussed with which it is possible to obtain zero or negative input capacitance.

INTRODUCTION

IN the course of carrying out ac Hall-effect measurements on photoconducting alkali-halide single crystals, the need arose for a push-pull preamplifier of very high input impedance and low noise to operate in the range from 10^2 to 10^4 cps. The resistance between Hall electrodes of these crystals, when photoconducting, usually fell within the range of 10 to 100 megohms. It was, therefore, desirable, in order to avoid loading of the Hall electrodes, to employ a preamplifier of at least ten times greater input impedance than the above values.

In order to obtain meaningful Hall constants, the electric field in the direction of the current in the sample must be known and homogeneous, at least near the Hall electrodes. This requirement precludes the use of dc or low-frequency ac in making Hall-effect measurements on these crystals as long as a constant light source is employed. For dc or low-frequency ac, the photocapacitive effect¹ in the crystals, which is caused by space-charge polarization, makes the electric field within the crystals exceedingly

inhomogeneous, with its greatest value near the current electrodes and a very small value at the midpoint between these electrodes. In order to eliminate this inhomogeneity, applied frequencies greater than about 10^2 cps must often be used.

It is relatively easy to achieve a high input impedance at low frequencies where the effect of shunt capacitance is negligible. However, at 5000 cps, a shunt capacitance of $3.2\mu\text{mf}$ has a reactance of only 10^7 ohms. Thus, to obtain an input impedance of 10^8 ohms or greater in the frequency range of interest, the input shunt capacitance must be made much lower than $3\mu\text{mf}$. At the same time, it is desirable that the high-impedance input leads be shielded to minimize pickup. The two requirements of low-input shunt capacitance and complete shielding are not mutually exclusive if the shield itself is driven from a low-impedance source with a voltage of the same phase and amplitude as the input signal. There will then be no current flowing through the capacitance between input lead and shield, and this capacitance will not contribute to the input impedance.

A first step toward the solution of the problem of low-input shunt capacitance has been taken by Keithley² who uses a cathode-follower input. The cathode of

* Then on leave from Armour Research Foundation of the Illinois Institute of Technology, Chicago, Illinois. Now at Texas Instruments, Inc., 6000 Lemmon Avenue, Dallas 9, Texas.

¹ J. R. Macdonald, *Phys. Rev.* **85**, 381 (1952); **90**, 364 (1953).

² J. F. Keithley, *Electronics* **22**, 98 (April, 1949).

this cathode follower supplies a signal to another cathode follower which, in turn, drives the shield. Because the gain of these cathode followers is appreciably less than unity, there is a small potential difference between shield and input lead. Therefore, only a portion of the effect of the capacitance between input lead and shield is cancelled with this arrangement and an effective input capacitance to ground of $4\mu\text{mf}$ or more still remains.

DESCRIPTION OF THE CIRCUIT

In the present solution to the problem the same general idea is employed, but the gain of the cathode-followers is made much closer to unity. However, even a unity gain will not reduce the effective input capacitance to zero. This capacitance, for a cathode follower is

$$C_{in} = C_{gp} + (1-G)C_{gk} + C_{ge}, \quad (1)$$

where C_{gp} , C_{gk} , and C_{ge} are capacitances from grid to plate, grid to cathode, and grid to ground, respectively, and G is the gain from grid to cathode. C_{gp} and C_{ge} are not affected by unity gain and may amount to $2\mu\text{mf}$ or more. The grid-plate capacitance may be largely eliminated, however, in the same fashion as the grid-cathode capacitance if the plate of the cathode follower is driven in phase and with approximately the same amplitude as the grid. If the gain from grid to cathode is denoted by G_1 and that from grid to plate by G_2 , the input capacitance for this arrangement is

$$C_{in} = (1-G_2)C_{gp} + (1-G_1)C_{gk} + C_{ge}. \quad (2)$$

An added benefit of driving the plate of the input cathode follower is that this arrangement results in a gain G_1 much closer to unity than that obtained without such a connection.

A practical realization of these ideas is shown in Fig. 1 where half of the push-pull input is presented. It will be noted that the plate of the input cathode-follower is driven by another cathode follower in series with it.† For low noise, the top pair of tube halves is a 12AY7. This tube is mounted in a ceramic socket on a separate, shock-mounted, subchassis which is entirely shielded as shown. The shield is in turn connected to the shield of the input coaxial lead and driven by the cathode of the input cathode follower. The grid-to-shield capacitance, therefore, becomes a part of C_{gk} . This arrangement ensures that C_{ge} will be very small since the only region where the input grid lead is unshielded and can have a direct capacitance to ground is within the tube envelope itself where there will be a small capacitance between grid lead and heater leads.

The bottom tube-half V_1 functions as a constant-current cathode load for V_2 and is equivalent to a very

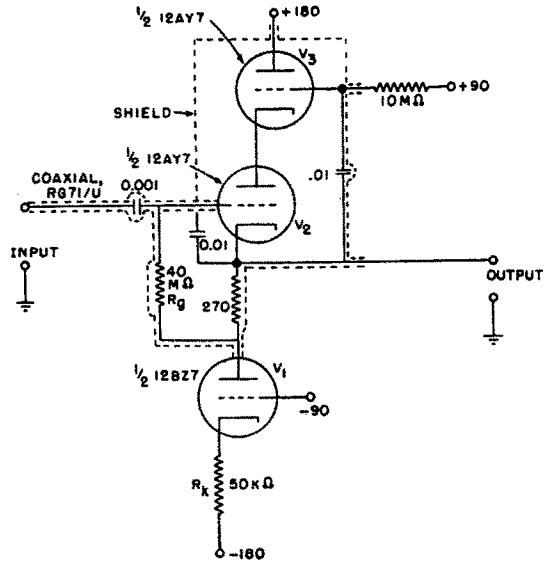

FIG. 1. High-input impedance circuit.

high resistance.³ This tube produces the same increase in cathode resistance as the cascaded cathode-follower circuit given by Smith and Kessler⁴ but in a simpler fashion. Such increase in cathode resistance is of material aid in making G_1 and G_2 very close to unity and further reducing C_{in} . The circuit of Fig. 1 is supplied from four 90-volt B batteries and employs a dc-heater supply.

COMPARISON OF THEORY AND EXPERIMENT

The input coaxial cable used was 15 in. long and the measured parallel capacitance and resistance between the input lead and ground with the cathode of V_2 grounded and the circuit inoperative were $43.2\mu\text{mf}$ and 35.4 megohms, respectively. With the circuit operating properly, the input resistance and reactance obtained as a function of frequency are shown in Fig. 2. These measurements were made with a General Radio type 716-C bridge. The input capacitance at the end of the coaxial cable varied from $0.2\mu\text{mf}$ at 100 cps to $0.35\mu\text{mf}$ at 5×10^4 cps. The input resistance is interesting in that it exhibits a resonance at about 3.2×10^8 cps, at which point it is infinite. Above this frequency, the input resistance is negative and decreases in magnitude with increasing frequency. This resonance behavior must arise from a small inductive phase shift in the feedback circuit; the resonance point could probably be shifted to higher frequencies if necessary.

The results of Fig. 1 show that the circuit satisfactorily fulfills the requirement of very high input impedance over the frequency range of interest. It will now be of interest to compare the theoretical perfor-

³ G. E. Valley, Jr., and H. Wallman, *Vacuum Tube Amplifiers*, Radiation Laboratory Series No. 18 (McGraw-Hill Book Company, Inc., New York, 1948), p. 432.

⁴ S. E. Smith and W. J. Kessler, *Proc. Natl. Electronics Conf.* 6, 129 (1950).

† Note added in proof—The idea of driving the plate of an input cathode-follower in this fashion seems to have been first suggested by S. Krakauer [Rev. Sci. Instr. 24, 496 (1953)]. The present circuit was developed independently of this work.

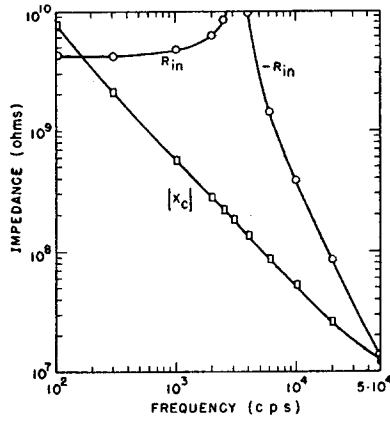

FIG. 2. Frequency variation of resistance and capacitive reactance to ground at coaxial cable input of high input impedance circuit.

mance of the circuit with actual measured results. It is easy to show that for midfrequencies

$$G_1 = \frac{1}{1 + \frac{1}{\mu_2(1+\mu_3)} + \frac{1}{g_{m2}[R_k(1+\mu_1)+r_{p1}] + \frac{\mu_3}{\mu_2(1+\mu_3)g_{m3}[R_k(1+\mu_1)+r_{p1}]}}}, \quad (3)$$

and

$$G_2 = G_1 - \mu_2(1-G_1) + \frac{r_{p2}}{R_k(1+\mu_1)+r_{p1}}, \quad (4)$$

where the subscripts on tube parameters refer to the tubes V_1 , V_2 , and V_3 in Fig. 1. Since the last three terms in the denominator of (3) will, in practical cases, be much less than unity, one finds to a very good approximation

$$1-G_1 \cong \frac{1}{\mu_2(1+\mu_3)} + \frac{1}{g_{m2}[R_k(1+\mu_1)+r_{p1}] + \frac{\mu_3}{\mu_2(1+\mu_3)g_{m3}[R_k(1+\mu_1)+r_{p1}]}}. \quad (5)$$

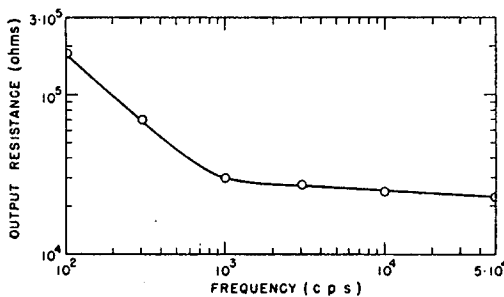

FIG. 3. Frequency variation of output resistance of high input impedance circuit with input grid lead floating.

For comparison, the gain of an ordinary cathode-follower with a constant-current cathode load is

$$G = \frac{1}{1 + \frac{1}{\mu_2} + \frac{1}{g_{m2}[R_k(1+\mu_1)+r_{p1}]}}. \quad (6)$$

Since the third term in Eq. (5) is usually negligible compared to the first two terms, and the second term in this equation can be made small compared to the first term, it is apparent that driving the plate of a cathode follower in the above fashion can reduce $(1-G_1)$ by approximately a factor of $(1+\mu_3)$ over that of the same cathode follower with a fixed-plate potential.

For the tubes and component values shown in Fig. 1, the computed theoretical gains lead to $1-G_1=0.00081$ and $1-G_2=0.027$. Without a driven plate, one would obtain $1-G=0.026$ for the same circuit values. Since $1-G_1=e_{gk}/e_g$ and $1-G_2=e_{gp}/e_g$, where e_{gk} and e_{gp} are the potential differences between grid and cathode, and grid and plate, and e_g is the input voltage, these quantities may be measured directly quite accurately with a vacuum-tube voltmeter. Experimental results obtained were $1-G_1=0.00175$ and $1-G_2=0.025$ for frequencies below 4000 cps. Above this frequency the experimental values increased slowly with frequency. The agreement between theoretical and experimental results is fairly good when it is considered that published, not measured, tube parameters were used in the computation of the theoretical gains.

Now, if we take these experimental values of $(1-G_1)$ and $(1-G_2)$ and compute C_{ge} from Eq. (2) using $C_{in}=0.2\mu\mu\text{f}$, $C_{gk}=43.2\mu\mu\text{f}$, and $C_{gp}\cong 2\mu\mu\text{f}$, we obtain $C_{ge}\cong 0.075\mu\mu\text{f}$. This result indicates that the shielding precautions were very effective in reducing the direct grid-to-ground capacitance. The effective theoretical input resistance of this circuit is approximately $R_{in}=R_g/(1-G_1)$. Using the measured value of 3.54×10^7 ohms for R_g and the experimental value of $(1-G_1)$, we find for R_{in} , 2×10^{10} ohms. The experimental value at low frequencies was 4.3×10^9 ohms. A large part of the difference may be ascribed to grid current and leakage. It is worth noting that the input time constant of the experimental circuit $C_{in}R_{in}$ was less than one millisecond, in spite of the high value of R_{in} .

With the circuit of Fig. 1 it is not possible, in general, to obtain the very high impedance ratio transformation which one might expect from initial considerations. With a gain of very nearly unity, the output impedance of the cathode follower V_2 should be very closely

TABLE I. Effect of added grid-to-ground resistance R_{ge} on measured output resistance r_o at 100 cps.

R_{ge} (ohms)	0	10^6	10^6	4.7×10^6	10^7	∞
r_o (ohms)	580	580	660	935	1350	1.8×10^5

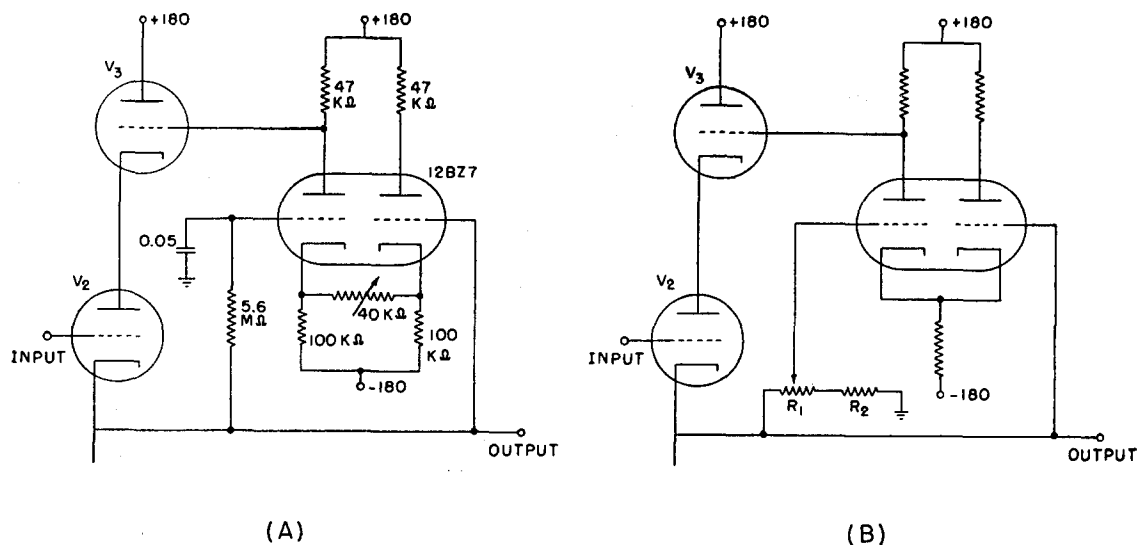

FIG. 4. Possible circuit modifications for obtaining zero or negative input capacitance. (A) For ac operation only. (B) For wide-range ac and dc operation.

$1/g_{m2}$. The measured value obtained with the input grid shorted to ground varied between 560 and 700 ohms, essentially independent of frequency, with different 12AY7's used for V_2 and V_3 . These values are in good agreement with the published value of g_m . However, when the output impedance was measured with the input grid floating, the results shown in Fig. 3 were obtained. The reason for this behavior is that the measuring voltage applied to the cathode of V_2 is coupled back into the grid of this tube by the capacitances C_{pk} and C_{gp} and the resistance R_g , and the circuit does not operate as a cathode follower. As the frequency increases, the effect of this undesirable feedback is reduced because the grid-ground impedance drops with frequency. The effect of added resistance between input grid and ground on the output impedance at 100 cps is presented in Table I. This table shows that the maximum impedance transformation ratio from 4.3×10^9 ohms to 580 ohms could be obtained by using the circuit of Fig. 1 to drive either another similar circuit or a simple cathode follower. Because of the high output impedance of the circuit at low frequencies, the driven shield is susceptible to pickup at these frequencies. In order to eliminate this effect, a second shield may be added to the input lead and this shield driven from another cathode follower whose grid is connected to the output of the circuit of Fig. 1. Driving the second shield in this way is preferable to grounding it, since the driven connection greatly decreases the capacitive loading produced by the capacitance between the two shields.

CIRCUIT MODIFICATION FOR ZERO INPUT CAPACITANCE

Theoretical considerations indicate that if the plate of V_2 were driven in phase with the input voltage but with greater amplitude, adjustment of this amplitude could be used to reduce the input capacity C_{in} to zero or to make it negative. The circuit of Fig. 4(A) was used to test this possibility and the expected results obtained. It was necessary to make $G_2 = 1.2$ in order to reduce C_{in} to zero. This large a value of plate-drive voltage in turn also caused G_1 to be slightly greater than unity, and the effective input resistance was reduced at all frequencies. With proper balancing and phase-shifting networks, it too could, however, probably be made considerably greater than 10^9 ohms and independent of frequency to relatively high frequencies. No instability whatsoever was observed with this circuit.

The circuit of Fig. 4(A) will not operate down to zero frequency. A suggested method of achieving such operation is indicated in Fig. 4(B), where $R_1 \ll R_2$. This circuit should maintain the large input dynamic range characteristic of a cathode follower and still allow the input capacitance to be reduced to zero by adjustment of the plate signal of the input cathode follower. Were one of the grids of the differential amplifier in this circuit held at constant potential and the other connected to the cathode of V_2 , only a small dynamic range could be covered because of cutoff of one or the other of the tube halves in the differential amplifier.

The author is very grateful to the Argonne National Laboratory for a visiting appointment.